

FRONT ELEVATION  
SCALE: 1:20

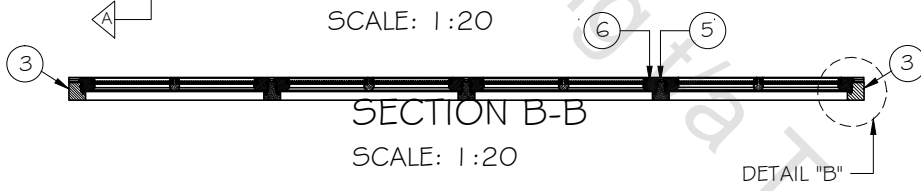

SECTION B-B  
SCALE: 1:20

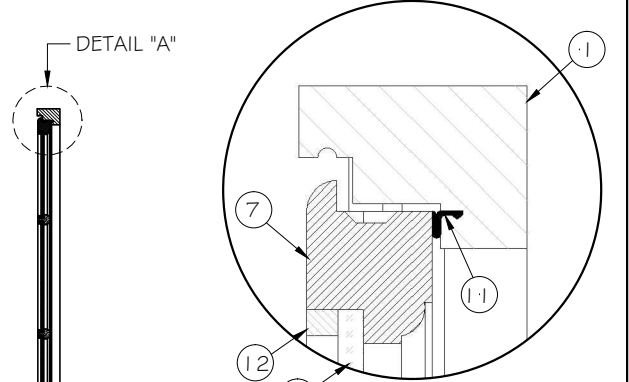

SECTION A-A  
SCALE: 1:20

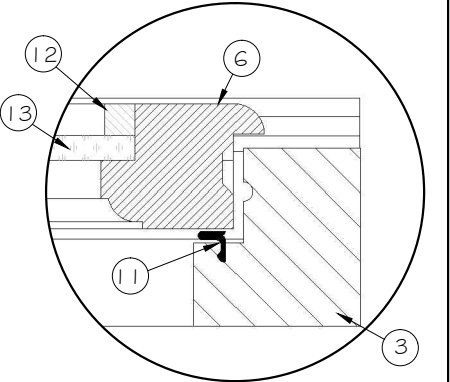

DETAIL-B  
SCALE: 1:2

NOTE: \* PERFORMANCE CATEGORY AAAMSA "A 1"  
 \* ALL JOINTS SEALED WITH GENKEM QAR I 07D4  
 \* SILICON TO BE PLACED ON FRAME BEFORE GLASS IS SEATED.  
 \* WOOD BEAD SILICONED & NAILED TO FRAME.

ITEM LIST

ITEM	DESCRIPTION	ITEM	DESCRIPTION
1	G/W HEAD	8	G/W SASH BARS
2	G/W CILL	9	NN 4 BAR HINGE 300 YP
3	G/W STILE	10	HANDLE WWH224 GAS SLIMLINE EGOLI
4	G/W TRANSOME	11	AQUAMAC 21
5	G/W MULLION	12	WOOD BEAD
6	G/W SASH STILE	13	GLASS 6.38mm LAMINATED
7	G/W SASH RAIL		

TAILORMADE JOINERY

TEL: 032 947 0435  
 PO BOX 260 UMHLALI 4390  
 GD522 SP GOODWOOD  
 SMALL PANE

DRAWN		DRAWING	
DATE	21/12/2012	NUMBER	REV.
SCALE	AS SHOWN	002	0