

FRONT ELEVATION

SCALE: 1:20

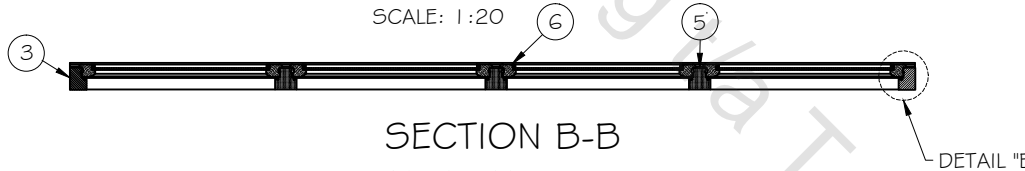

SECTION B-B

SCALE: 1:20

DETAIL "A"

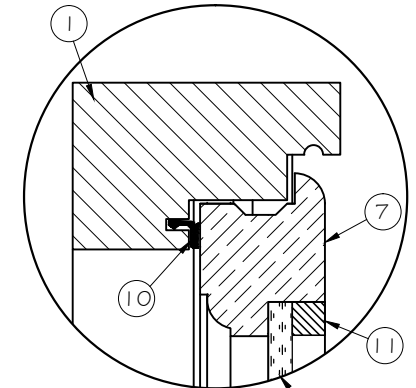

DETAIL A

SCALE: 1:2

SECTION A-A

SCALE: 1:20

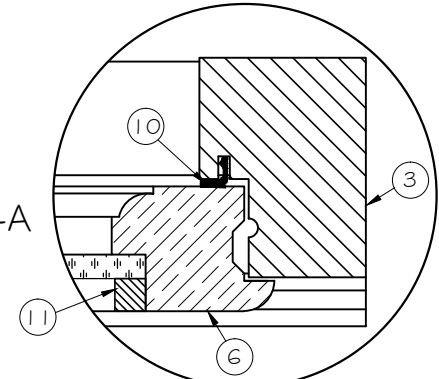

DETAIL B

SCALE: 1:2

- NOTE:** *PERFORMANCE CATEGORY AAAMSA "A1"
 *ALL JOINTS SEALED WITH GENKEM QAR107D4
 *SILICON TO BE PLACED ON FRAME BEFORE GLASS IS SEATED.
 *WOOD BEAD SILICONED & NAILED TO FRAME.

ITEM LIST

ITEM	DESCRIPTION	ITEM	DESCRIPTION
1	GW HEAD	8	NN 4 BAR HINGE 300 YP
2	GW CILL	9	HANDLE WWH224 GAS SLIMLINE EGOLI
3	GW STILE	10	AQUAMAC 21
4	GW TRANSOME	11	WOOD BEAD
5	GW MULLION	12	GLASS 6.38mm LAMINATED
6	GW SASH STILE		
7	GW SASH RAIL		

TAILORMADE JOINERY

TEL: 032 947 0435

PO BOX 260 UMHLALI 4390

GD522 FP GOODWOOD
 FULL PANE

DRAWN		DRAWING	
DATE	11/12/2012	NUMBER	REV.
SCALE	AS SHOWN	001	3