

FRONT ELEVATION

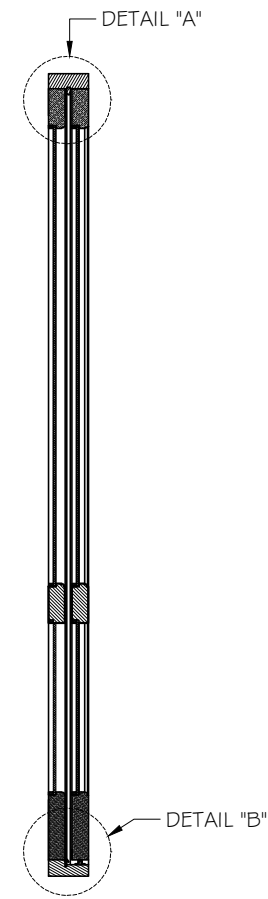

SECTION A-A

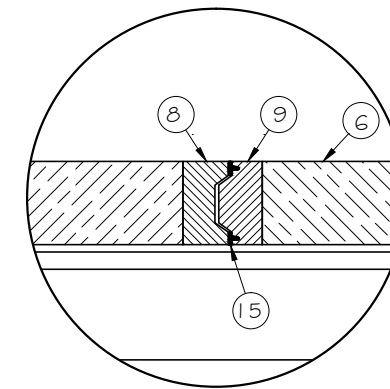

DETAIL D

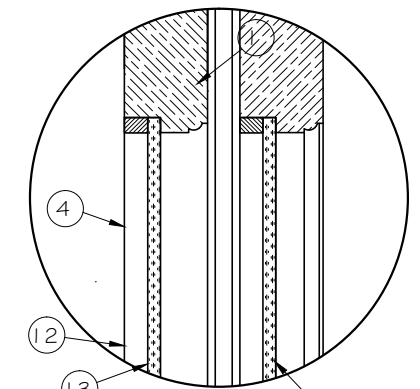

DETAIL A

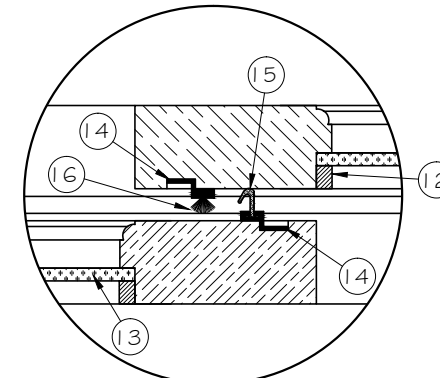

DETAIL E

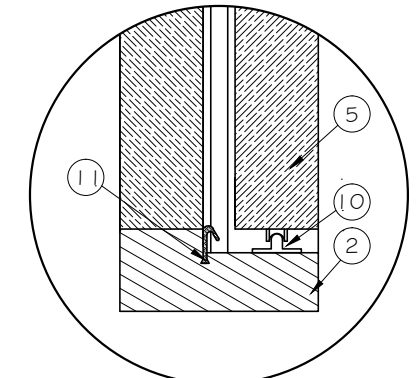

DETAIL B

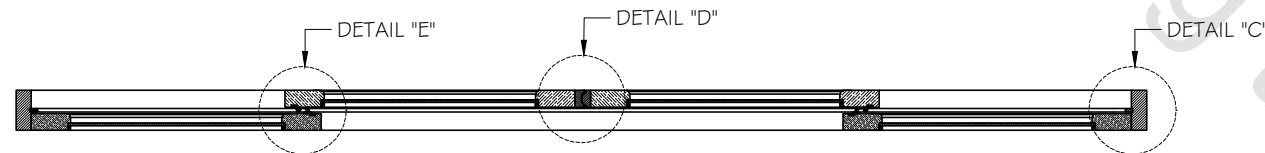

SECTION B-B

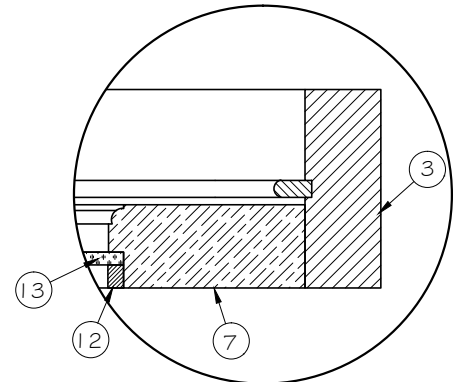

DETAIL C

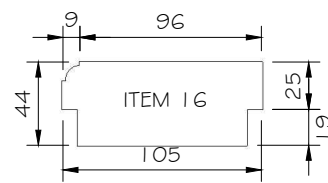
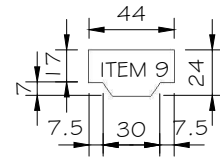
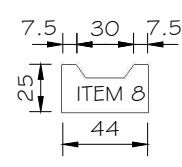
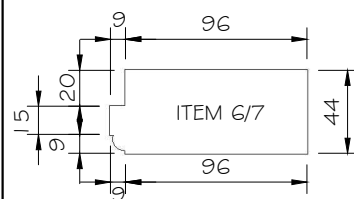
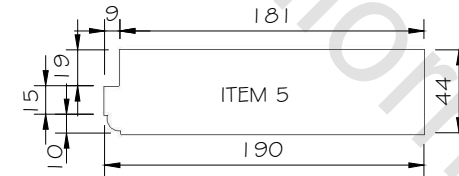
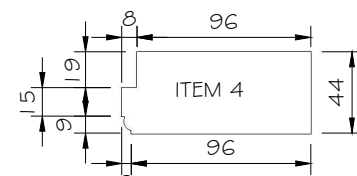
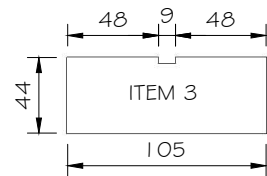
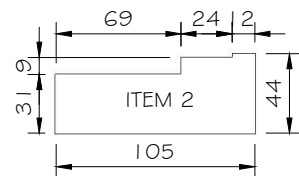
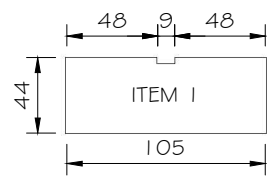

NOTE: *PERFORMANCE CATEGORY AAAMSA "A1"
 *ALL JOINTS SEALED WITH GENKEM QAR107D4
 *SILICON TO BE PLACED ON FRAME BEFORE GLASS IS SEATED.
 *WOOD BEAD SILICONED & NAILED TO FRAME.

ITEM LIST

ITEM	DESCRIPTION	ITEM	DESCRIPTION
1	SLIDING DOOR HEAD	9	MALE BEAD
2	SLIDING DOOR CILL	10	ALU. T-TRACK
3	SLIDING DOOR STILE	11	AQUAMAC 124
4	SLIDING DOOR TOP RAIL	12	WOOD BEAD
5	SLIDING DOOR BOTTOM RAIL	13	GLASS 6.38mm LAMINATED
6	SLIDING DOOR STILE (SLIDE)	14	WOOLPILE HOLDER
7	SLIDING DOOR STILE (FIXED)	15	Q-LON
8	FEMALE BEAD	16	WOOLPILE
		17	105mm BOTTOM RAIL

TAILORMADE JOINERY

TEL: 032 947 0435
 PO BOX 260 UMHLALI 4390
 DOUBLE SLIDING DOOR WITH
 105mm CENTER RAIL
 DSL2800FP

DRAWN		DRAWING	
DATE	05/03/2013	NUMBER	REV.
SCALE	1:4 - 1:20	009	4